

EXTRA-EX2/21

Technical conditions for mounting luminaire ENG

11.03.2026/ rev.3
www.vyrtych.cz

EXTRA-EX2/21

FTZÚ 25 ATEX 0056X

Ex II 3G Ex nR IIC T6 Gc

Ex II 2D Ex tb IIIC T85°C Db

IECEX FTZÚ 25.0020X

Ex nR IIC T6 Gc

Ex tb IIIC T85°C Db

IP66/ IP67, class I



Keep safe and proper usage by following these instructions.
Keep them for future reference.

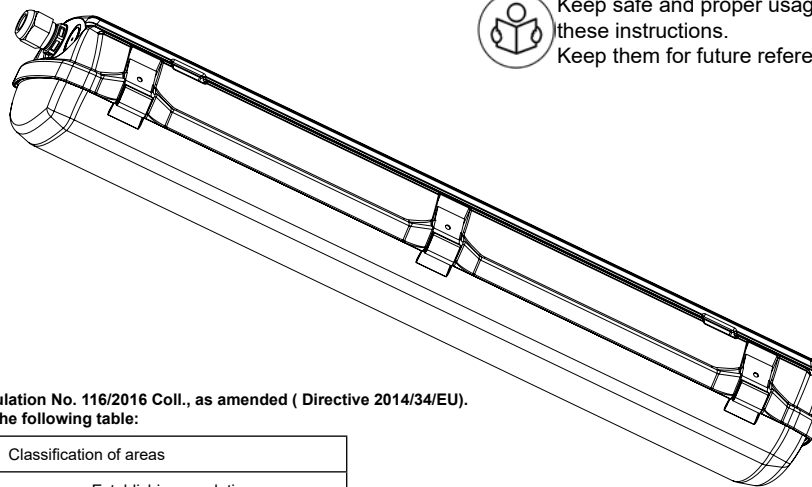

These luminaires comply with the requirements of Government Regulation No. 116/2016 Coll., as amended (Directive 2014/34/EU).
They are intended for use in explosive atmospheres as specified in the following table:

Hazardous area	Designation of external influences	Classification of areas	
		Designation	Establishing regulation
Danger of explosion of inflammable dusts	BE3N1	ZONE 21, ZONE 22	ČSN EN 60079-14 / EN 60079-14 ČSN EN 60079-10-2/ EN 60079-10-2
Danger of explosion of inflammable gases and vapours	BE3N2	ZONE 2	ČSN EN 60079-14/ EN 60079-14 ČSN EN IEC 60079-10-1/ EN IEC 60079-10-1

Permissible operating temperature range:

Type	Ta	W	IP	Temperature class	Maximum surface temperature
EXTRA-EX2/21-G-L06-YYY-1700-0ND/0D2-08-PD	-30°C - +50°C	8	66/67	T6	85°C
EXTRA-EX2/21-G-L06-YYY-2500-0ND/0D2-08-PD	-30°C - +50°C	15	66/67		
EXTRA-EX2/21-G-L06-YYY-5000-0ND/0D2-08-PD	-30°C - +50°C	28	66/67		
EXTRA-EX2/21-G-L12-YYY-3300-0ND/0D2-08-PD	-30°C - +60°C	17	66/67		
EXTRA-EX2/21-G-L12-YYY-4000-0ND/0D2-08-PD	30°C - +55°C	22	66/67		
EXTRA-EX2/21-G-L12-YYY-5000-0ND/0D2-08-PD	-30°C - +55°C	26	66/67		
EXTRA-EX2/21-G-L12-YYY-7000-0ND/0D2-08-PD	-30°C - +55°C	35	66/67		
EXTRA-EX2/21-G-L12-YYY-10000-0ND/0D2-08-PD	-30°C - +45°C	52	66/67		
EXTRA-EX2/21-G-L15-YYY-3750-0ND/0D2-08-PD	-30°C - +60°C	19	66/67		
EXTRA-EX2/21-G-L15-YYY-4900-0ND/0D2-08-PD	-30°C - +55°C	25	66/67		
EXTRA-EX2/21-G-L15-YYY-7500-0ND/0D2-08-PD	-30°C - +50°C	40	66/67		
EXTRA-EX2/21-G-L15-YYY-8300-0ND/0D2-08-PD	-30°C - +35°C	46	66/67		
EXTRA-EX2/21-G-L15-YYY-12550-0ND/0D2-08-PD	-30°C - +45°C	63	66/67		
EXTRA-EX2/21-G-L15-YYY-16700-0ND/0D2-08-PD	-30°C - +35°C	82	66/67		
EXTRA-EX2/21-G-L15-YYY-20000-0ND/0D2-08-PD	-30°C - +35°C	100	66/67		

Rated voltage and frequency:

for LED drivers HELVAR: 220-240V, 50/60Hz, 220-240V DC
for LED drivers TCI: 220-240V, 50/60Hz, 220-240V DC

EXTRA-EX2/21-G-Lββ-YYY-δδδδ0-εεεε-08-PD -

IP66 - according to the standards ČSN EN 60079-0
IP67 - according to the standards ČSN EN 60529

Luminaire marking:

VYRTYCH
Židněves 116, 294 06 Březno, Czech Republic

① EXTRA-EX2/21-G-Lββ-YYY-δδδδ0-εεεε-ζζ-PD
② 220-240V, 50/60Hz, 220-240V DC, class I, 50W
③ -30°C ≤ ta ≤ +50°C, IP66/ IP67
④ FTZÚ 25 ATEX 0056X/ IECEX FTZU 25.0020X
⑤ Ex II 3G Ex nR IIC Tx Gc/ Ex nR IIC Tx Gc
⑥ Ex II 2D Ex tb IIIC Txx°C Db/ Ex tb IIIC Txx°C Db
⑦ art.n.: 60 327 ⑧ Product Type: W011204012-84AA0PD66000S

123456
⑩

Luminaire marking:

1. Name of the luminaire

EXTRA - name of the luminaire
EX2/21 - luminaire certified for zone 2/21
G - type of the luminaire enclosure
Lββ - luminaire length
YYY - CRI/ CCT
δδδδ0 - designation of the luminous flux of the LED source
εεεε - connection type
ζζ - internal marking
PD - polycarbonate opal cover

2. Designation of the operating voltage, frequency, insulation class of the luminaire power

3. Designation of the allowable ambient temperature range, and luminaire IP protection rating

4. Certificate designation

- FTZÚ - abbreviation of the certification authority that issued the certificate
- 25 - year of issuance of the certificate
- ATEX / IECEX - abbreviation of certificate type
- 0056X / 25.0020X - certificate number

5. Luminaire protection marking against the risk of explosion from flammable gases and vapors

6. Luminaire protection marking against the risk of dust explosion

7. Item number

8. Luminaire product number

9. Notified body number

10. Lin code

Luminaire dimensions:

Type	A (mm)	B (mm)
EXTRA-EX2/21-G-L06-YYY-55500-EEEE-PD	670	460
EXTRA-EX2/21-G-L12-YYY-55500-EEEE-PD	1280	880
EXTRA-EX2/21-G-L15-YYY-55500-EEEE-PD	1580	1000

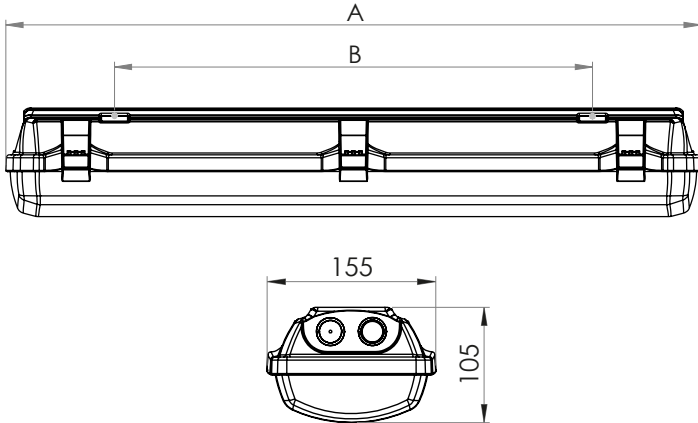

Standard equipment:

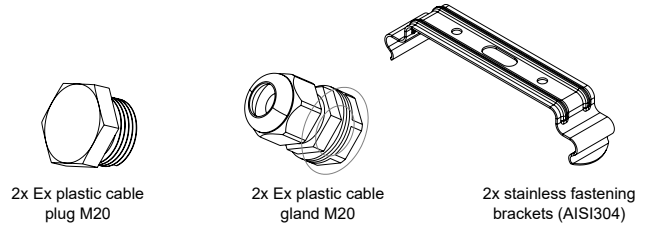

The luminaire is normally equipped with 3x openings with a diameter of 20.2 mm. The wall thickness of the luminaire is 2.5 mm. When using your own cable glands, they must comply with the required type of seal, IP protection rating, temperature range (the same as for the glands we supply), and other technical parameters. Always carry out the installation according to the installation instructions provided by the gland manufacturer. In case of any doubts, please contact technical support at: podpora@vyrtych.cz

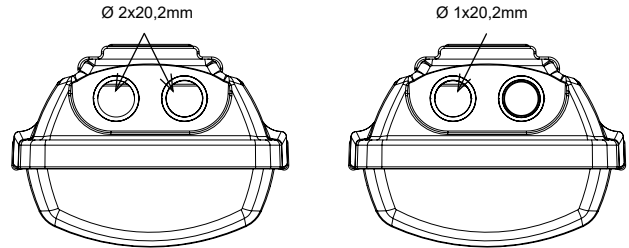

⚠ Additional holes may only be drilled in locations specified by the manufacturer. Always use a step drill to ensure the correct hole diameter. Carefully deburr the edges of the hole until smooth. If any other part of the luminaire is damaged, do not continue using it.

Types of mounting:

Mounting procedure using fastening brackets directly onto the supporting surface

With cable suspender

With wall bracket - angle 45°

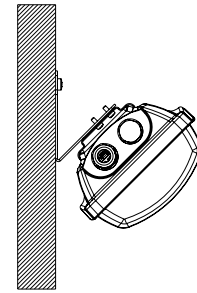
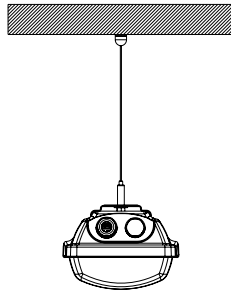
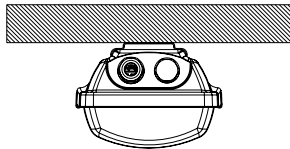
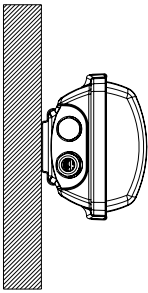

With protective cage

With wire suspension

Mounting procedure using a bracket on a pole

Mounting procedure using a bracket on a pipe

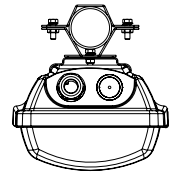
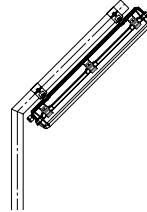
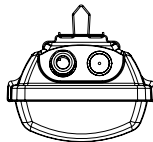
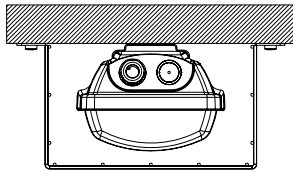

The light fixture can be installed in both covered and uncovered outdoor areas.

Picture. 1
Conditions of outdoor assembly

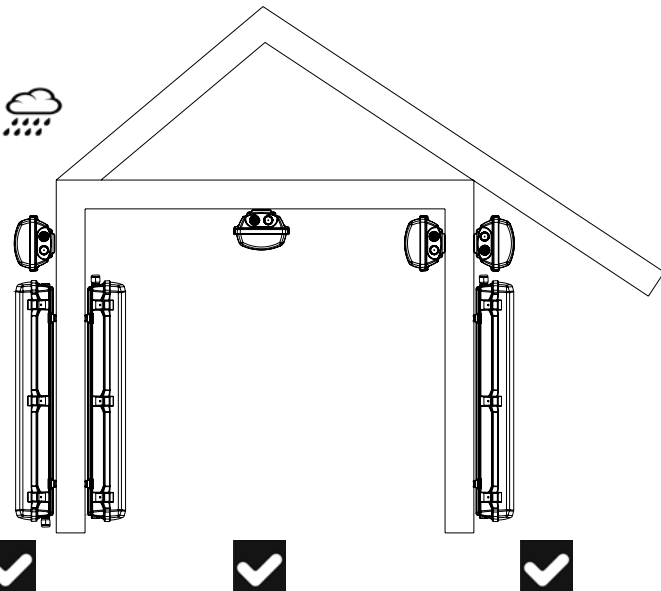

Minimum distance of the light fixture from the wall

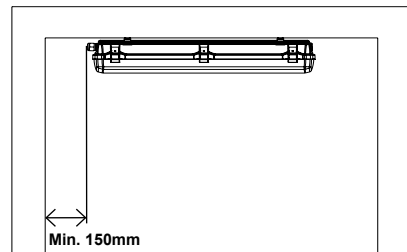
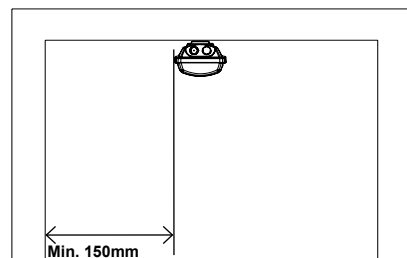

Mounting procedure using fastening brackets directly onto the supporting surface:

1

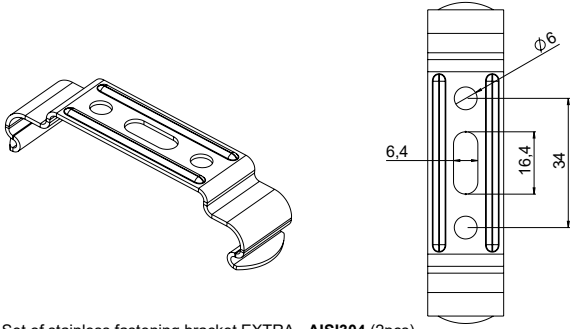

67492 - Set of stainless fastening bracket EXTRA - AISI304 (2pcs)
67493 - Set of stainless fastening bracket EXTRA - AISI316L (2pcs)

2

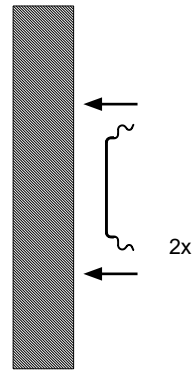

3

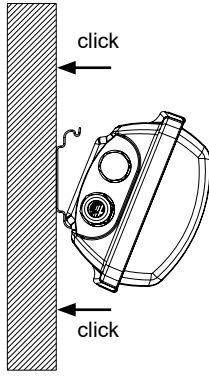

4

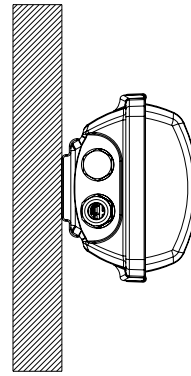

Mounting with cable suspender:

1

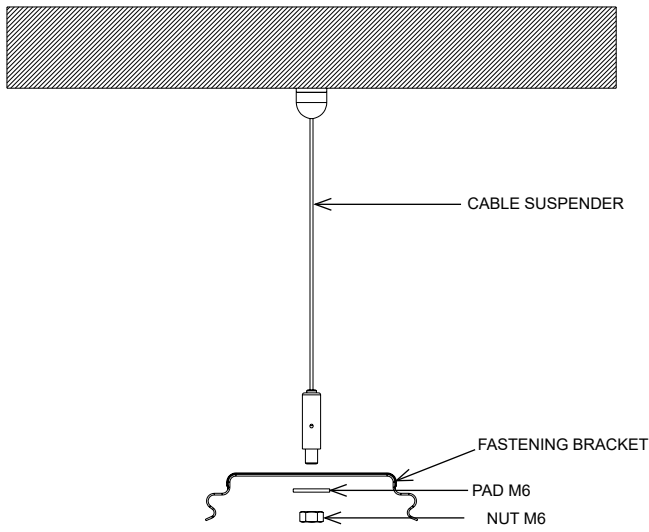

3575 - Cable suspender - 3 m (2 pcs)

2

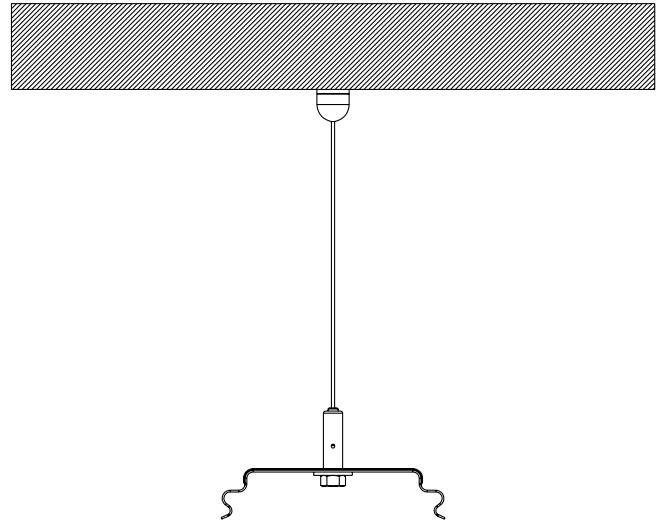

3

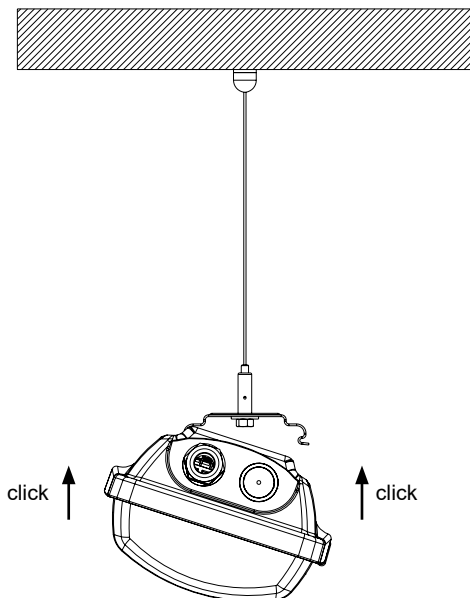

4

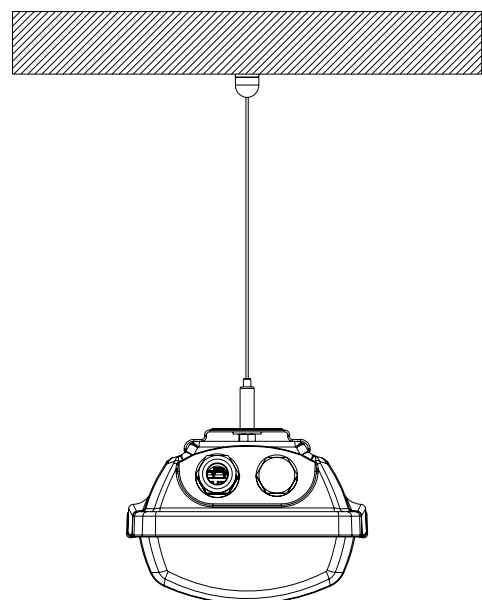

Mounting procedure using a pole brackets:

1

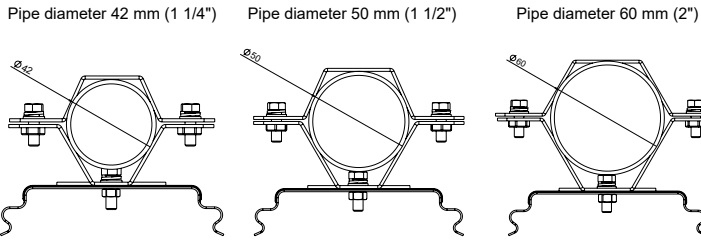

60091 - Set of pole brackets Ø 42 mm (1 1/4") AISI304 (2 pcs) / 60090 - Ø 50 mm (1 1/2") / 60089 - Ø 60 mm (2")
 66931 - Set of pole brackets Ø 42 mm (1 1/4") AISI316 (2 pcs) / 66930 - Ø 50 mm (1 1/2") / 66929 - Ø 60 mm (2")

2

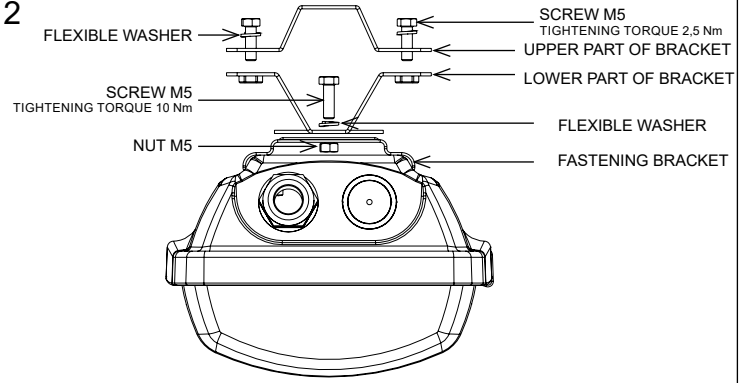

3

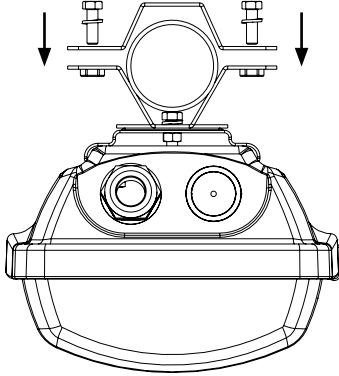

4

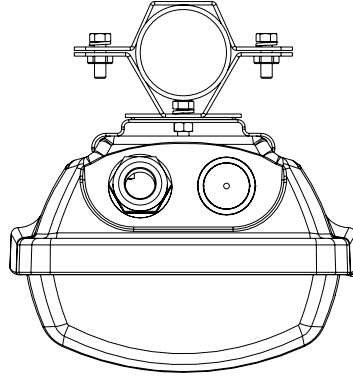

Mounting procedure using a 45° wall bracket:

1

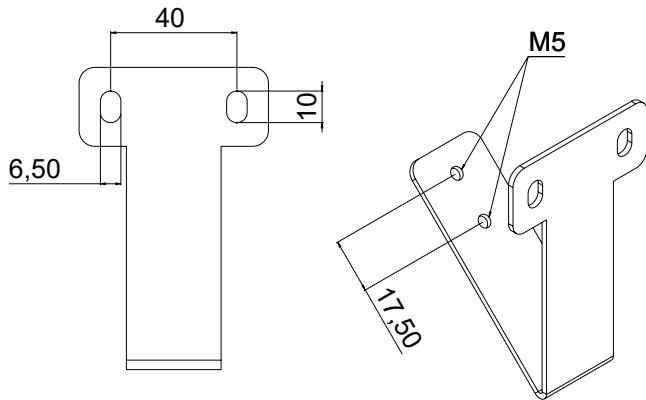

34607 - Set of wall bracket - 45° angle EXTRA, AISI304 (2 pcs)
 67005 - Set of wall bracket - 45° angle EXTRA, AISI316 (2 pcs)

2

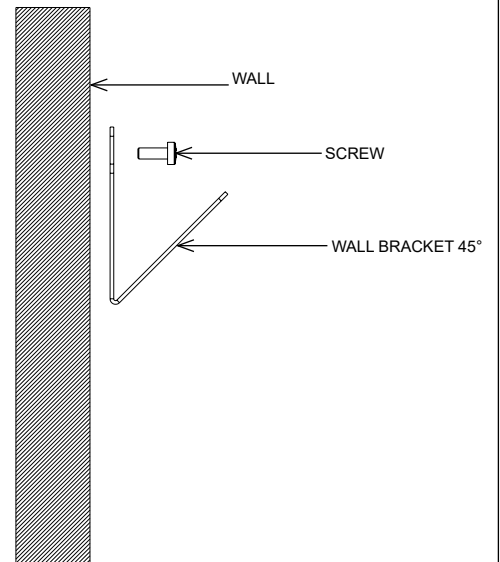

3

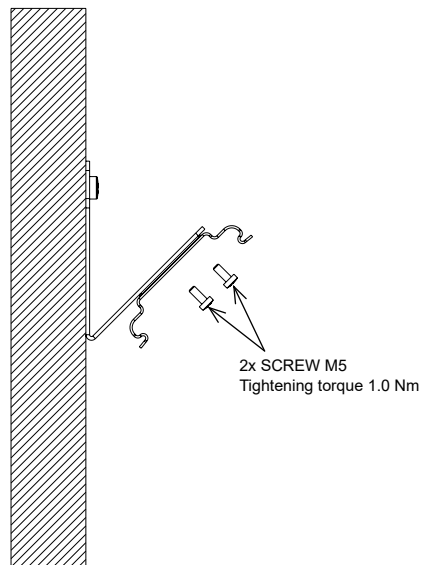

4

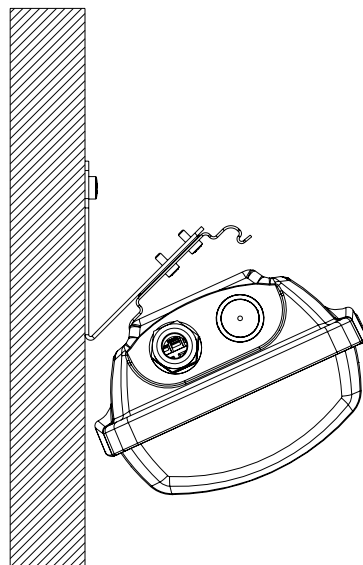

5

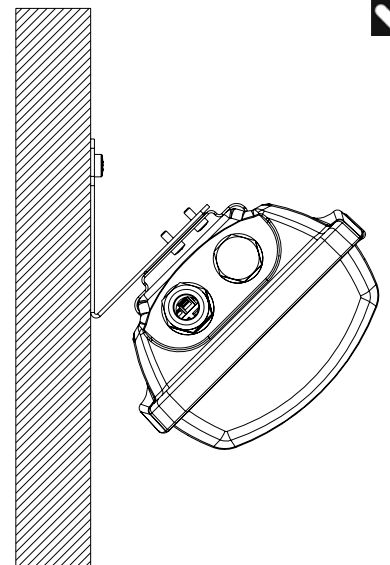

Mounting procedure with protective cage:

1

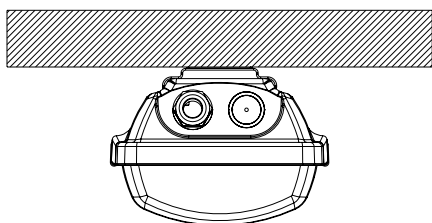

2

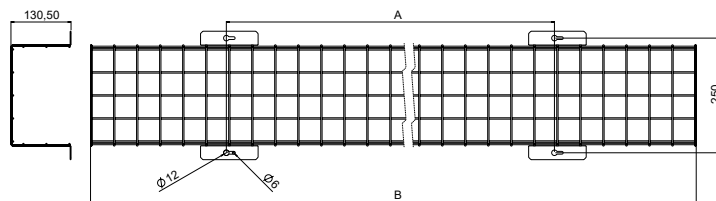

		A	B
20041	Protective cage EXTRA, EUROPA - L06	400	700
20042	Protective cage EXTRA, EUROPA - L12	700	1300
20043	Protective cage EXTRA, EUROPA - L15	1000	1600

3

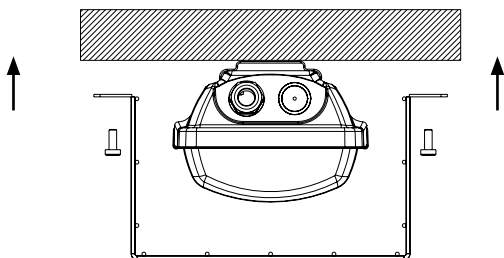

4



Mounting procedure with wire suspension:

1

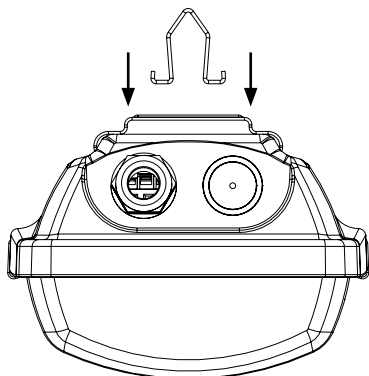

2

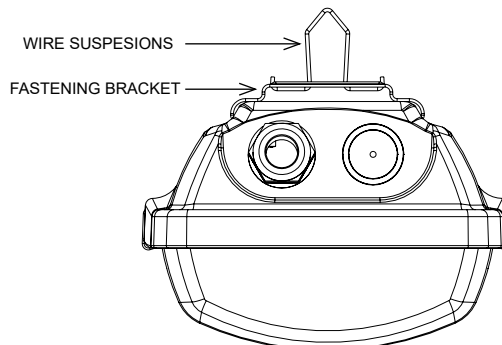

69110 - Set of wire suspension EXTRA (2 pcs)

3

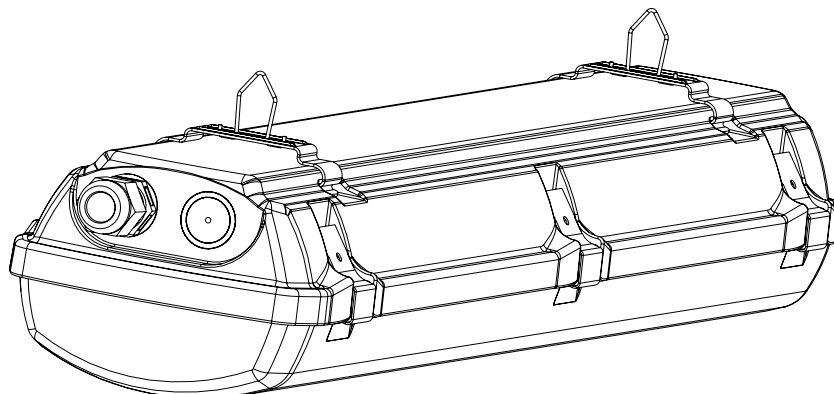

Grounding of metal cable glands with armored cable: 65909 – EXTRA equipment – cable glands M20 for armored cable
 69111 – EXTRA equipment – cable glands M25 for armored cable
 67516 – EXTRA – grounding washer for cable glands – 1 pc

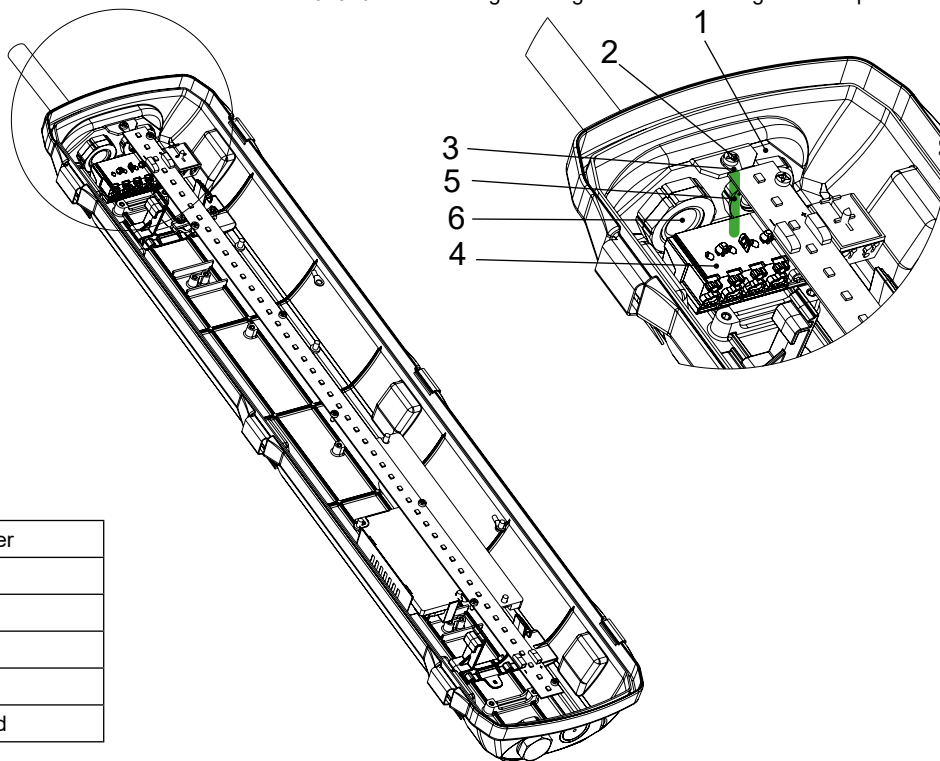

1	Grounding washer
2	M4 screw
3	Cable eye
4	Terminal block
5	Protective wire
6	Metal cable gland

Luminaire construction

	Luminaire components
1	Luminaire housing
2	Luminaire cover
3	Ex cable gland
4	LED driver
5	Terminal block
6	LED module
7	Stainless clamp
8	Reflector bracket
9	Metal reflector
10	Supply cable

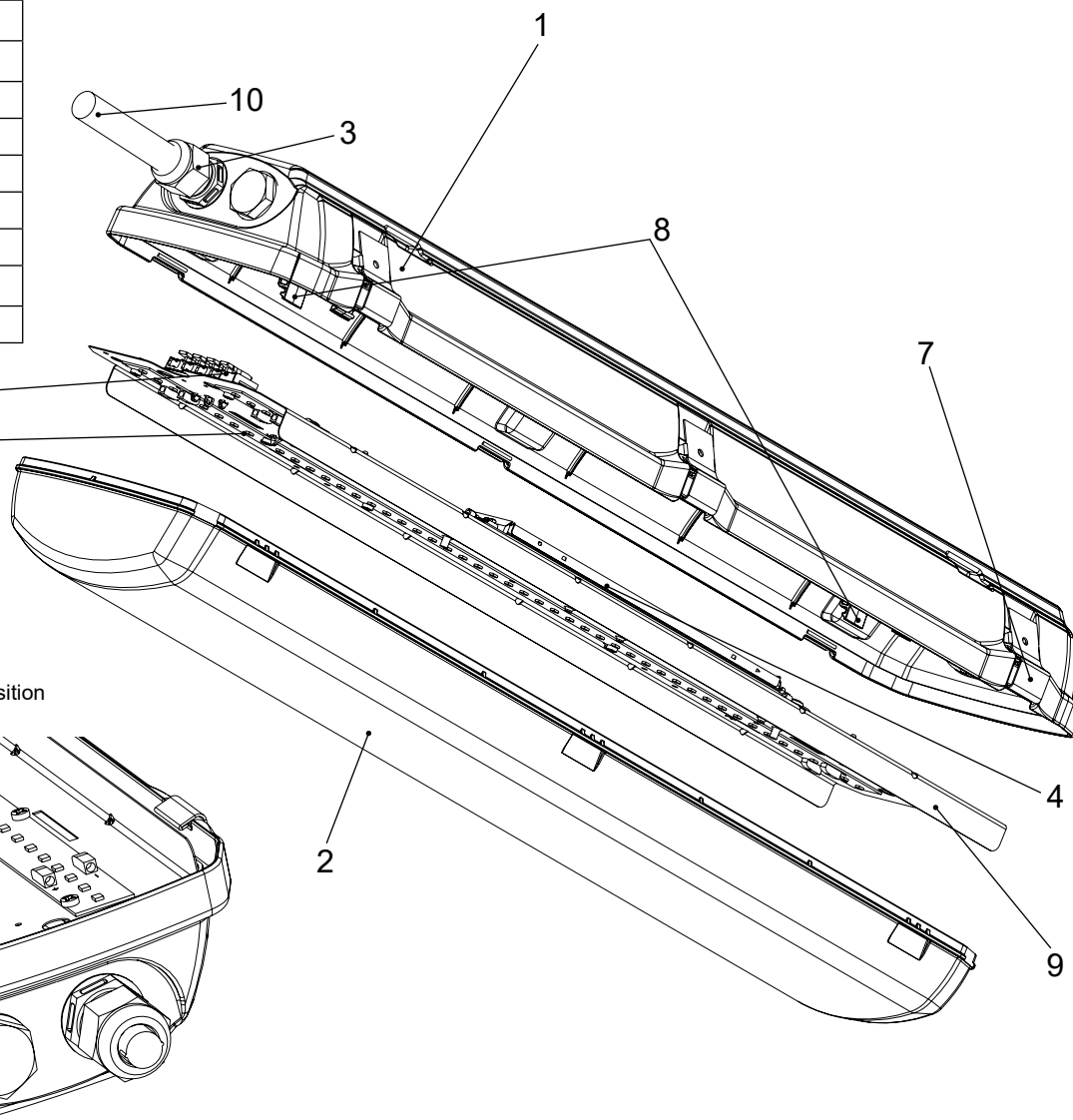

Metal reflector in default position

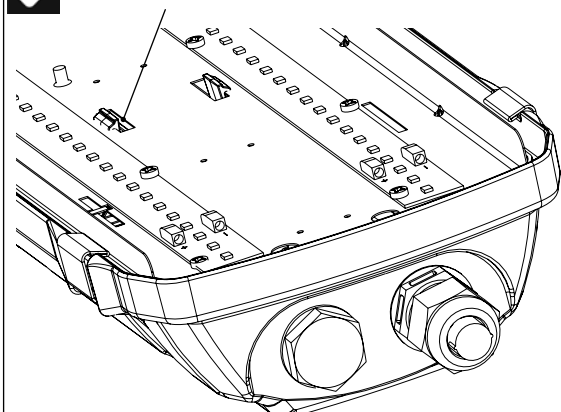

Installation instructions:

1. Remove the plastic cover from the luminaire (2).
2. Release the reflector from the holders (8) and hang the reflector on the safety cables.
3. Remove the accessory bag.
4. Install the cable gland and the cable plug on the luminaire. Tighten to the luminaire with a torque of 2.7 Nm. Each gland must be secured with two nuts.
5. Snap the stainless steel clips (7) provided with the fixture onto the fixture hinges.
6. Feed the supply cable (10) through the cable gland (3). Properly tighten the cable glands until the sealing rubber washer is slightly deformed; tightening torque 2.0 Nm.

Cable gland	Sealing area	Tightening torque of the cable gland	Minimum operating temperature of the cable gland
M20x1,5	7 - 13 mm	2.0 Nm	-30°C+60°C

7. Plug the power cable into the free part of the supply terminal block (5) as follows:

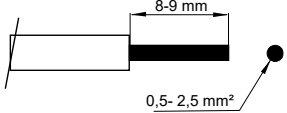
CLAMP	TYPE OF LUMINAIRE						STRIPPING THE WIRE
	0ND	0D2	LM3	LM3A	LD3D2	CB	
L1	phase wire	phase wire	charging phase wire	charging phase wire	charging phase wire	phase wire	
L2	-	-	switched phase wire	switched phase wire	switched phase wire	-	
DA+	-	DALI +	-	-	DALI +	-	
DA-	-	DALI -	-	-	DALI +	-	
N	neutral wire	neutral wire	neutral wire	neutral wire	neutral wire	neutral wire	
⊕	protective wire	protective wire	protective wire	protective wire	protective wire	protective wire	

0ND - ON/OFF driver **0D2** - DALI2 driver **LM3** - Emergency unit 3H + ON/OFF driver **LM3A** - Emergency unit 3H Autotest + ON/OFF driver

LD3D2 - Emergency unit 3H DALI + DALI2 driver **CB** - Central battery system

8. Return the metal reflector (9) to the default position.
 9. Attach the luminaire cover (2) and snap the clips (7) into place.
- *After closing the fixture, the clips can only be opened using a screwdriver, see picture 3.

Maximum number of lights connected to a circuit breaker: Maximal short circuit current must not be higher than 10kA.

Typ	B10A	B16A	C10A	C16A
EXTRA-EX2/21-α-L06-γγγ-1700(2500)-0ND-08-PD	31	50	52	85
EXTRA-EX2/21-α-L06-γγγ-5000-0ND-08-PD	23	38	39	64
EXTRA-EX2/21-α-L06-γγγ-1700(2500)-0D2-08-PD	31	50	52	85
EXTRA-EX2/21-α-L06-γγγ-5000-0D2-08-PD	34	55	57	93
EXTRA-EX2/21-α-L12-γγγ-3300/4000/5000-0ND-08-PD	23	38	39	64
EXTRA-EX2/21-α-L12-γγγ-10000-0ND-08-PD	13	21	22	36
EXTRA-EX2/21-α-L12-γγγ-3300/4000/5000-0D2-08-PD	34	55	57	93
EXTRA-EX2/21-α-L12-γγγ-10000-0D2-08-PD	17	28	29	47
EXTRA-EX2/21-α-L15-γγγ-3750-0ND-08-PD	23	38	39	64
EXTRA-EX2/21-α-L15-γγγ-7500-0ND-08-PD	13	21	22	36
EXTRA-EX2/21-α-L15-γγγ-12550(16700)-0ND-08-PD	13	21	22	36
EXTRA-EX2/21-α-L15-γγγ-20000-0ND-08-PD	13	21	22	36
EXTRA-EX2/21-α-L15-γγγ-3750-0D2-08-PD	34	55	57	93
EXTRA-EX2/21-α-L15-γγγ-7500-0D2-08-PD	18	30	31	50
EXTRA-EX2/21-α-L15-γγγ-12550(16700)-0D2-08-PD	17	28	29	47
EXTRA-EX2/21-α-L15-γγγ-20000-0D2-08-PD	17	28	29	47
EXTRA-EX2/21-α-L15-γγγ-4900-0ND-08-PD	23	38	39	64
EXTRA-EX2/21-α-L15-γγγ-4900-0D2-08-PD	34	55	57	93
EXTRA-EX2/21-α-L15-γγγ-8300-0ND-08-PD	13	21	22	36
EXTRA-EX2/21-α-L15-γγγ-8300-0D2-08-PD	18	30	31	50
EXTRA-EX2/21-α-L12-γγγ-7000-0ND-08-PD	23	38	39	64
EXTRA-EX2/21-α-L12-γγγ-7000-0D2-08-PD	34	55	57	93

Functionality Test of the Emergency Lighting System:

To ensure proper operation of the luminaire, the enclosed emergency lighting test record must be followed.
 For testing the functionality of the emergency luminaire, place the magnet (luminaire accessory 63023) at the location of the signal LED, marked with a TEST label, see picture 2.
 If the emergency source switches off before the specified autonomy time has elapsed, even though the battery is fully charged, the battery must be replaced with a new one.
 Note: The battery reaches full capacity after approximately three charging/discharging cycles.

Picture 2
Functionality test of the emergency lighting system

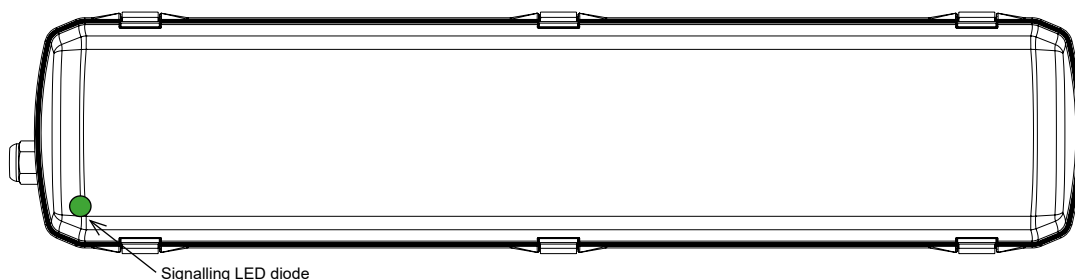

63023

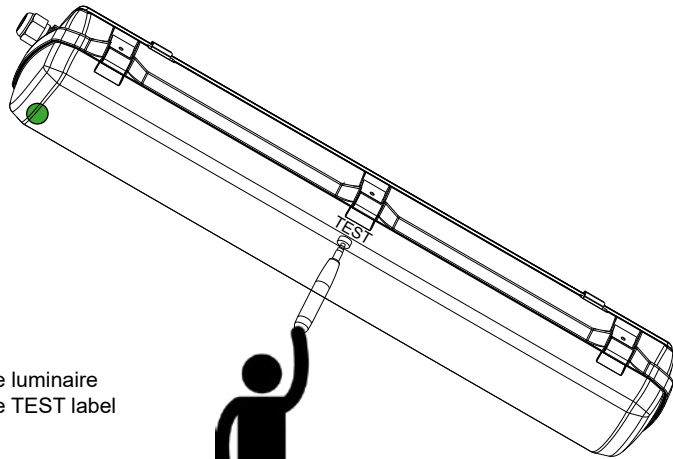
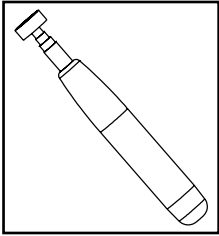

 Use a magnet to touch the luminaire cover at the location of the TEST label



Battery replacement:

Battery replacement is necessary once the luminaire no longer meets the requirements of its rated operating duration. Replace the battery in a non-explosion-hazardous environment.

1. Disconnect the luminaire from the power supply.
2. Using a screwdriver, release the clips on the optical cover (picture 3).
3. Remove the luminaire cover.
4. Release the reflector from the holders (8) and hang the reflector on the safety cables.
5. Disconnect and remove the old battery using a Phillips screwdriver to unscrew the two screws holding the battery (see picture 4).
6. Mount the new battery (mark installation date).
7. Connect the battery to the emergency unit.
8. Reinstall the reflector in its original position.
9. Fit the luminaire cover back in place and secure the clips.
10. Reconnect to power and verify emergency operation.
11. Confirm that battery charging is indicated properly.

WARNING: Use only batteries of the same type and parameters as indicated on the battery label.

Picture. 3
Release the clips using a flat-head screwdriver

 Using a flat-head screwdriver, carefully lever to unlock the clips on the luminaire.

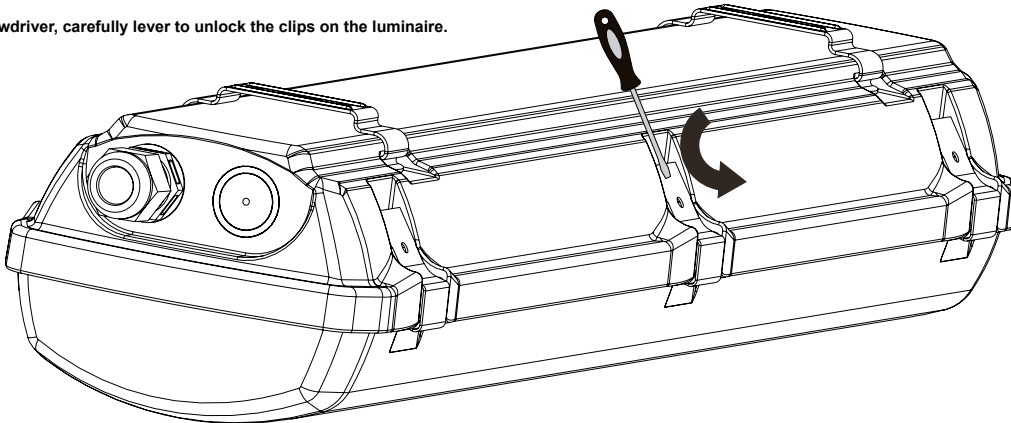

Picture. 4
Disconnecting and removing the battery using a cross-head screwdriver

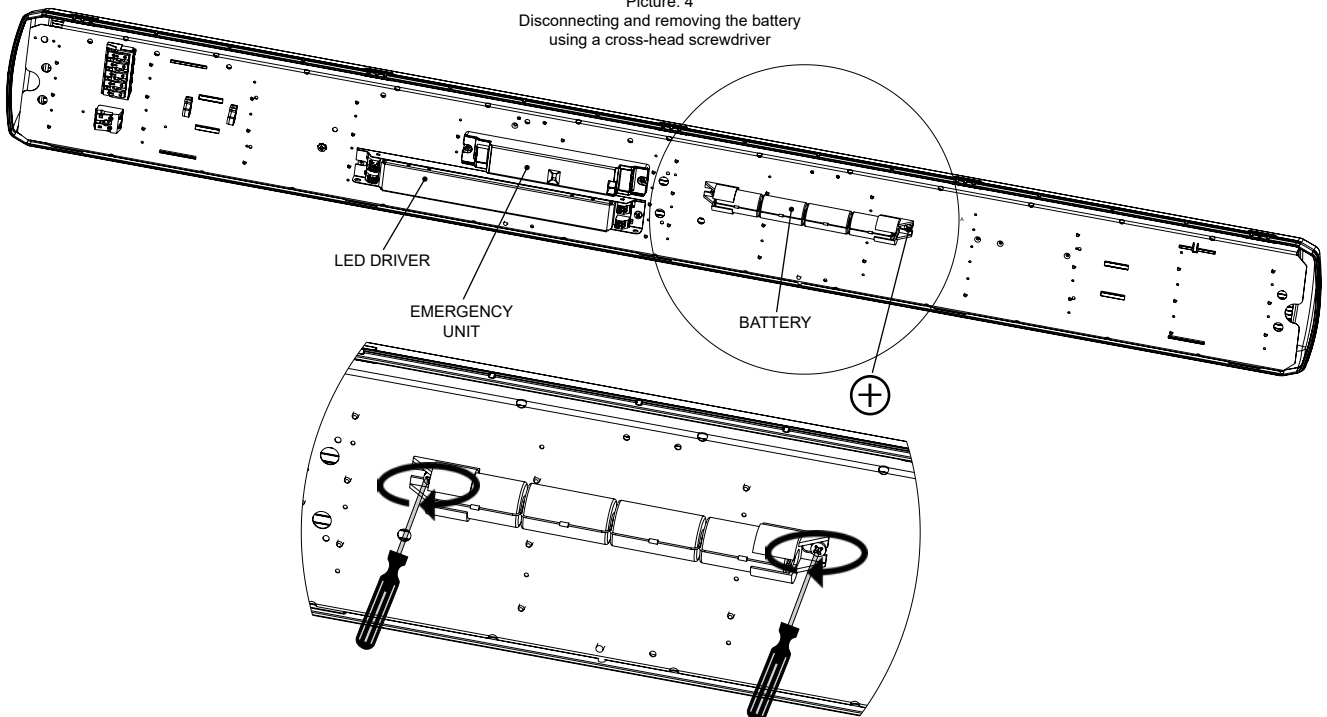



During the installation and operation of luminaires in explosive atmospheres, it is essential to follow the relevant safety measures in accordance with national regulations and standards. EXTRA-Ex2/21 luminaires are plastic, dust-tight, and water-tight fixtures designed for illuminating areas with a risk of explosion.

Connection of the luminaire to the electrical network may only be carried out by a person with the appropriate qualification, in accordance with the valid regulation on electrical competence. When installing the luminaire, ESD safety precautions must be observed using appropriate tools and equipment.

The light source, seals, cable glands, or plugs in this luminaire may only be replaced by the manufacturer, its authorized service technician, or a similarly qualified person. Any modification or replacement of components that affect explosion protection is strictly prohibited. Repairs may only be performed by qualified personnel and only using original spare parts.



WARNING!!!

Potential risk of electrostatic charging.

The luminaire must be installed in such a way that accidental contact with people and parts of the luminaire is prevented.

This luminaire is intended for fixed installation only.

Clean the luminaire using a damp cloth only. Regular cleaning intervals must be observed.

Do not open while under voltage.

Replace any cracked protective cover immediately.

The battery inside the luminaire may only be replaced with a battery of the same type and specifications!!

The manufacturer is not liable for any damage resulting from failure to follow the installation instructions.



The manufacturer is registered in the take-back system for electrical and electronic equipment and waste according to applicable regulations, and also participates in the packaging take-back and recycling system operated by EKO-KOM. (EK-F06070058).

Description of luminaire variants by control method:

ND - ON/OFF luminaire

D2 - DALI2 luminaire

LM3A - ON/OFF luminaire + emergency 3h, Autotest

LM3 - ON/OFF luminaire + emergency 3h

LA3D2 - DALI2 luminaire + emergency 3h, AUTOTEST

LM3D2 - DALI2 luminaire + emergency 3h

LMD3D2 - DALI2 luminaire + emergency 3h, DALI

Description of luminaire variants by connection type:

ND-1F - ON/OFF luminaire, 3x2.5 mm²

ND-3F - ON/OFF luminaire, 5x2.5 mm²

D2-1F - DALI2 luminaire, 5x2.5 mm²

D2-3F - DALI2 luminaire, 7x2.5 mm²

LM3A-3F - ON/OFF luminaire + emergency 3h, AUTOTEST, 5x2.5 mm²

LM3-3F - ON/OFF luminaire + emergency 3h, 5x2.5 mm²

LA3D2-3F - DALI2 luminaire + emergency 3h, AUTOTEST, 7x2.5 mm²

LM3D2-3F - DALI2 luminaire + emergency 3h, 7x2.5 mm²

LMD3D2-3F - DALI2 luminaire + emergency 3h, DALI, 7x2.5 mm²

i Max. conductor cross-section 2.5 mm²

Accessories to order:

In luminaire data sheet.

Basic instructions for luminaire users:

For users of luminaires

For users of emergency luminaires

For DALI system users

i After clicking on the QR code, you will be redirected to the relevant website.